

# Gregor van Egdome

*Creative technical problem solver*

 Portfolio of Industrial Design

# Clickup

REUSABLE BEVERAGE CUP THAT ATTACHES TO ITSELF

Clickup is an innovative startup with a bright idea: why not make the common reusable polycarbonate drinking cups connectable to each other? These cups are mainly used during festivals and in clubs, with huge crowds gathering to party. If it's your turn to buy a round of drinks, you can either choose to do some finger-acrobatics and hope you won't spill any drinks, or you can buy a separate tray. Both solutions have their downsides, particularly to their users and their environment.

Imagine being able to take a row of 8 freshly tapped beers in each hand, without any help.

The young entrepreneurs behind Clickup approached me with this idea and a homemade model and asked to come up with a producible, hygienic, structurally sound and usable design.

## Intensive

To start out the 9 week project we identified the stakeholders, researched their (latent) needs and defined the project boundaries. During a very intensive ideation phase, rapid iterations of the connection mechanism were designed, prototyped and immediately tested. On average 2 different ideas were printed (using FDM) per day. Almost all different working principles were user-tested.

The aesthetics of the product have been reworked from the ground up, with cues taken from nature as inspiration for the curves and details of the product. The main shape was derived from the iconic Dutch beer glass.

## Smooth

The connection of two glasses is a smooth, self explanatory action with distinct feedback to the user. Once two glasses have been connected, they cannot disconnect unintendedly. The entrepreneurs are currently working with an engineering and injection moulding company to start up production.



Freelance project



9 weeks, part time



2009





# Cable connection 3 COMPLETELY NEW CONCEPTS TO CONNECT MICRO-ELECTRONICS



Graduation project



22 weeks, full time



2009

Sony Ericsson is a joint venture between the premier Japanese consumer electronics brand Sony and Swedish telecom multinational Ericsson. During a 5 month graduation internship I developed innovative solutions for the physical and electrical interconnection of product parts.

## Bluetooth

The solutions were primarily developed for application in wireless accessories (e.g. Bluetooth headsets) but can also be deployed in other fields.

To gain insight in the problems of interconnection, solutions and products of Sony Ericsson and competitors alike were subjected to a thorough analysis phase. This provided data about the mechanical strength and durability. To determine what the requirements of end users regarding these factors are, user tests and interviews were conducted. To determine the priorities of internal requirements, several employees from a great range of disciplines were asked about their opinion. The following prioritization of problems was used to determine a vision for the project:

1. Physical size of the solution
2. End-user durability
3. Manufacturability

Based on the insights of the analysis phase, ideas were generated for three solution areas:

- Mechanical fixation
- Electrical interconnection
- Bend relief

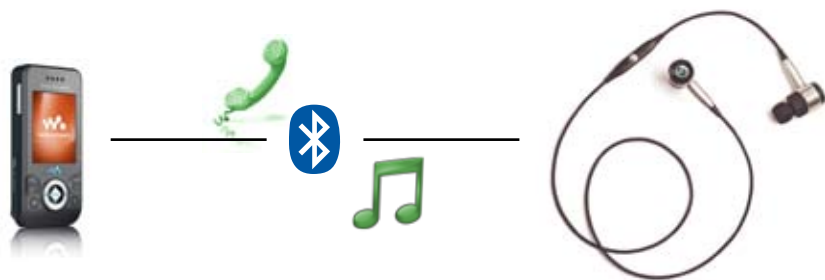

Current situation:



Analysis phase

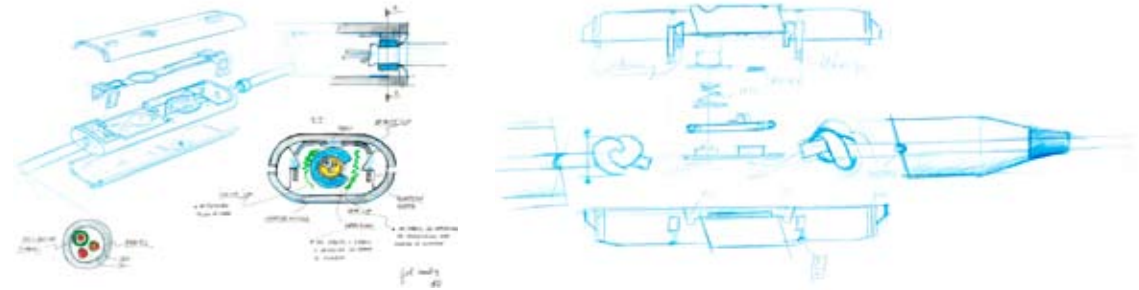

Analysing existing products



Cable breakage after repeated bending

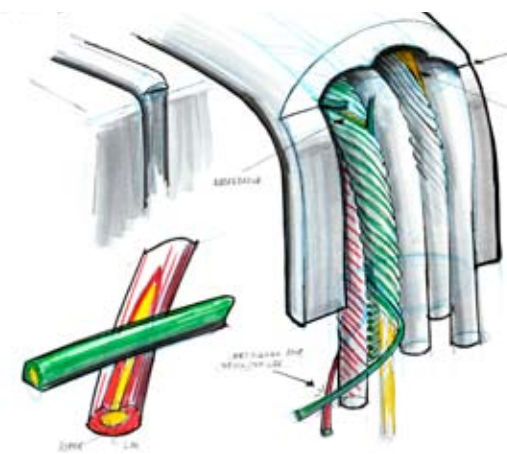
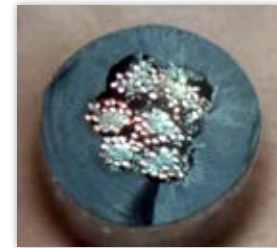

### **Current situation**

The majority of headset and headphone products of both Sony Ericsson and others use standard solutions for the problems outlined. For mechanical fixation, tying a knot in the cable is by far the most popularly used solution. For electrical interconnection, the cable is soldered to the PCB of the product by hand. The solutions for bend relief typically consist of rubber-like parts placed around the cable.

The mechanical performance of these solutions is relatively good. However, Sony Ericsson considers size of its accessories an important competitive advantage. All three existing solutions take up considerable amounts of space, especially in the relatively small accessories. For some product parts, up to 60% of the volume is dedicated to the solutions.

The use of manual assembly influences the overall quality of the products and the amount of discarded products during production. This project was aimed at finding solutions for these problems.

### **New solutions**

The three new solutions employ innovative technology to solve the outlined problems, each with very different working principles.

Because of a strict non-disclosure agreement, this is the only information which is allowed to be published.



In total, 72 models were made ...



... and tested for durability.

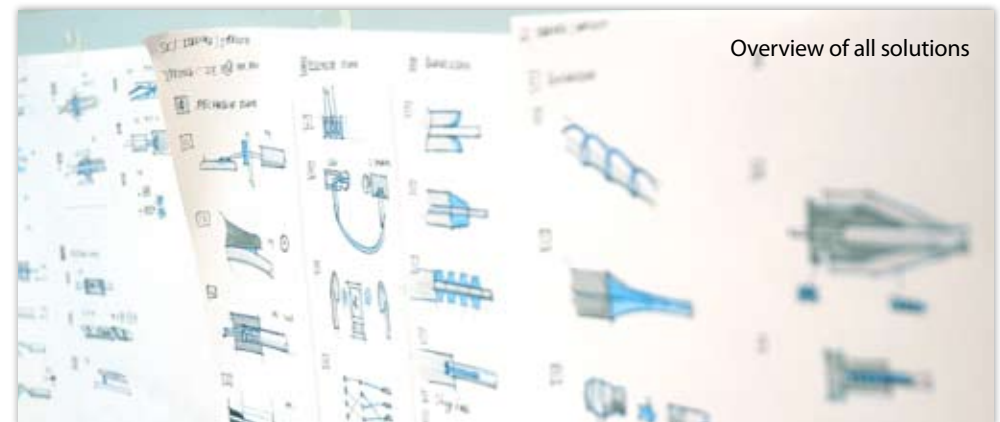
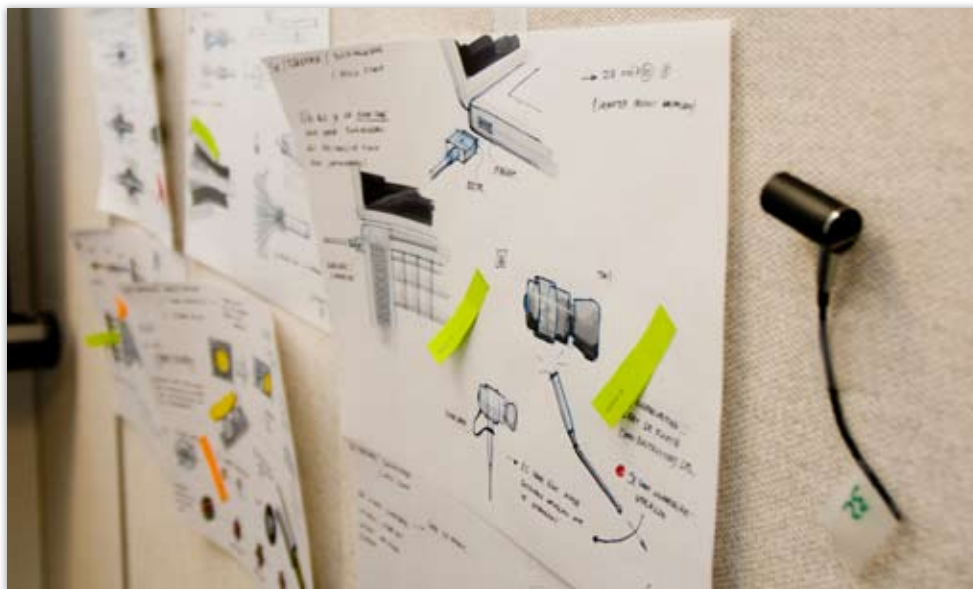

Overview of all solutions

# HYPE-CUT Enclosure

REDESIGN OF OF A LASER CUTTING SYSTEM ENCLOSURE



Group project



18 weeks, part time



2008

Penta Chutian is a joint venture between a Chinese manufacturer of laser cutting systems (Chutian Laser Co.) and an Italian manufacturer of laser sources (Cutlite Penta).

## New markets

Penta Chutian wants to expand their sales to Europe, a highly competitive but very interesting market for laser cutting systems. The current design of their HYPE-CUT system did not meet the expectations of European clients regarding aesthetics and safety.

Among a host of other problems, the aesthetics of the machine did not appeal to European customers. Also there were several safety issues barring a market entry.



Original machine

## China

In order to create more freedom for different overall aesthetics, we created two concept routes. During a five week trip to China we met with our client and worked together with local students to create endless overall designs. Those were distilled into six concepts, three for each concept route.

After a presentation to the company the chosen concept was further refined when we arrived back in Holland.

The final design uses a mouse- and keyboardless console which is free to be placed anywhere around the machine for maximum ease of use. The enclosure can be produced on equipment already available to Penta Chutian. The new aesthetics were tested and found to appeal to the majority of customers. Several safety features were integrated to ensure maximum safety and compliance to European rules and regulations.

### Analysis phase



### Design creation phase



### Concept phase



### Optimization phase

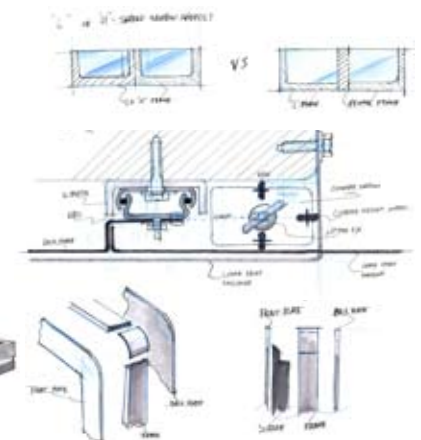

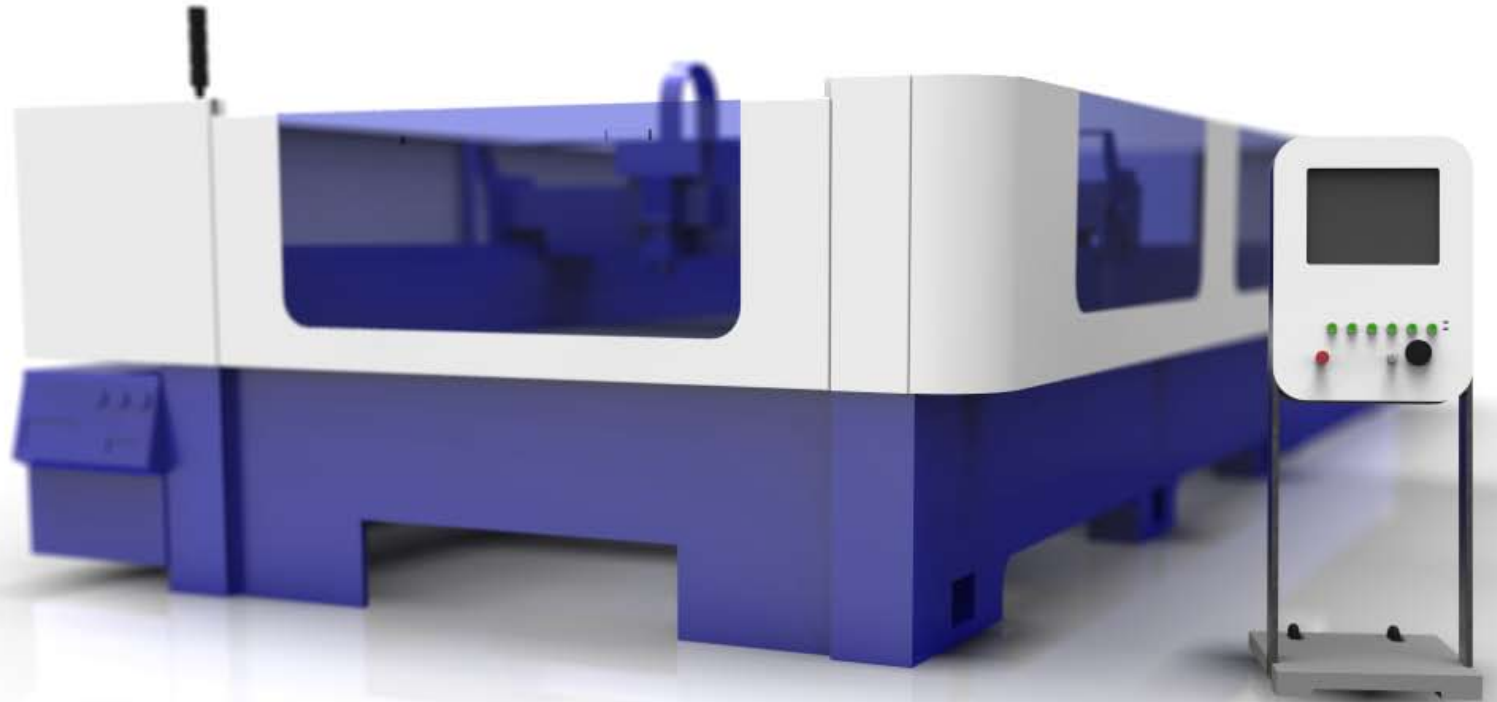
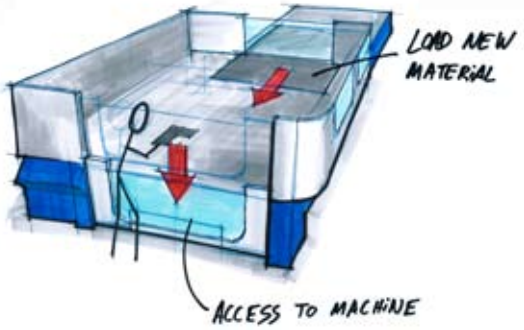

## Air freshner

RECHARGABLE FRAGRANCE DISPENSER FOR GIVAUDAN

Givaudan is the leading manufacturer of fragrances and flavourings. Companies like Procter & Gamble use Givaudan's fragrances in their air fresheners. In an effort to think along with their customers, Givaudan asked to design the "Air Freshner of 2012", with specific detail to sustainability.

**Business model**

One of the key features behind the design is a different business model. Air fresheners on the market today are without exception "throwaways", which in itself is very environmentally unfriendly.

Besides using "green" technology and materials, my vision was to double the cost price to make room for durable materials and techniques, and earn back the loss in profit through the sales of fragrance refills.



Individual project



± 10 weeks, part time



2007

**Proud**

The product has a flexible power plug, which stands straight up in the air when the product is working on its battery, seemingly proud of its independence of the power outlet. The fragrance is delivered through the use of small piézo elements, one for each of the two different fragrances.

An intelligent microprocessor controls which of the two is delivered, and in what strength. This is done based on the time of the day and day of the week, by a randomized program. The user maintains control by setting the strength (10 levels) and a button to instantly change the fragrance.

**E-Ink**

With the built-in battery, the product can function for about two months without recharging. When power is almost drained, a bright red dot on the power plug com-

## Project analysis

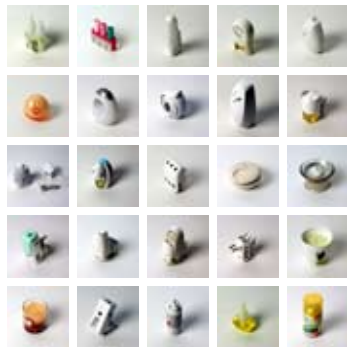

## Idea creation

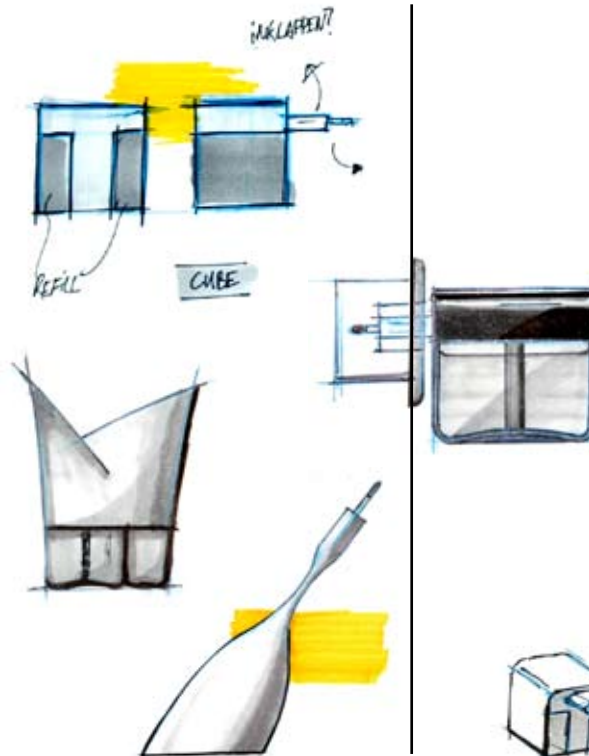

## Concept development

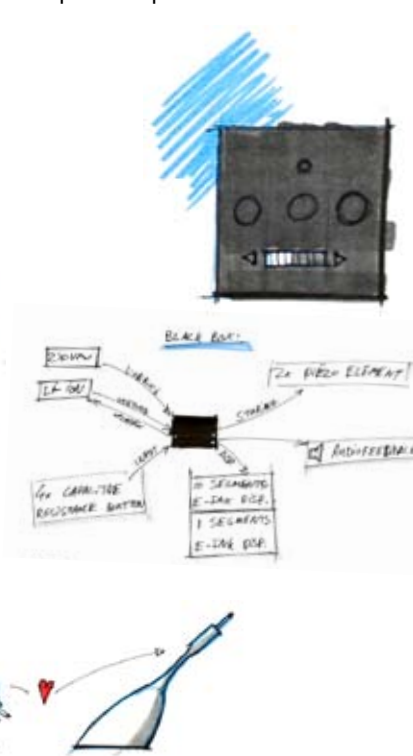

## Details design

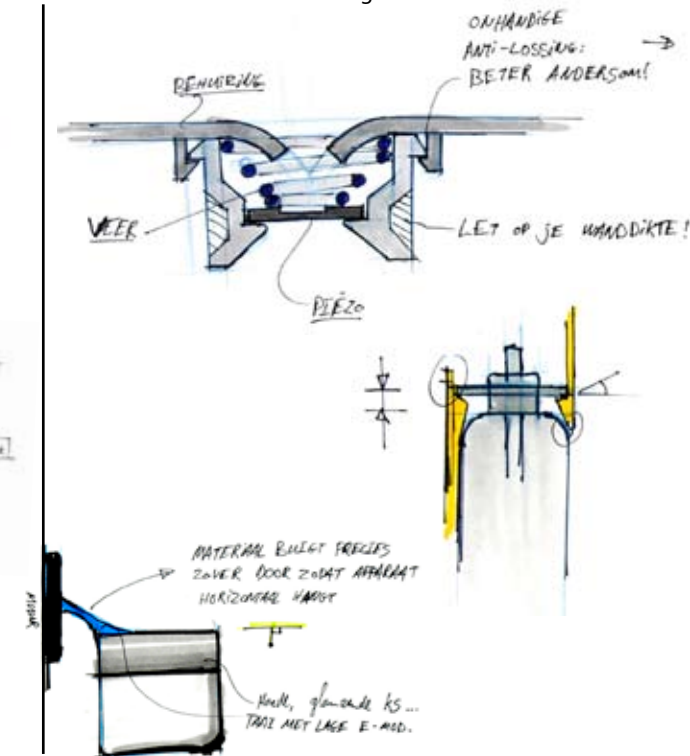

municates the need for a recharge. This is an E-Ink display, also known as electronic paper, which preserves its state when power is lost. The 10 segment strength display also uses this technology. The interface buttons use capacitive resistance technology with audio feedback.

**Engineering focus**

A combination of exact measurements and mathematics was used to determine the specifications of the battery. An existing product using piëzo elements was disassembled and examined. Calculations were made on several critical parts of the product. All parts were designed as a full solid 3D-CAD model, used for finite element analyses (FEA), technical drawings and rendering the final product. For most of the procurable active parts of the product suppliers were suggested.

A working 1:1 model was made to demonstrate use of the flexible power plug and the connection of the refills.

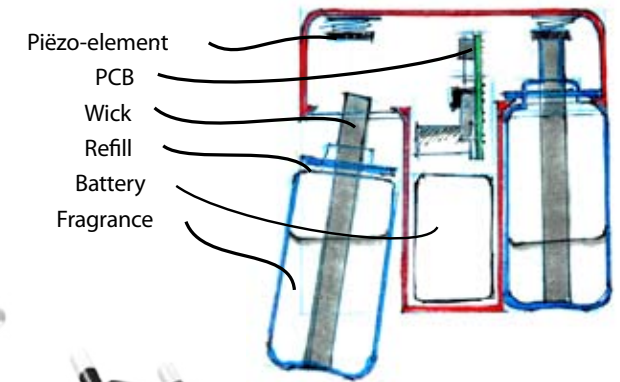
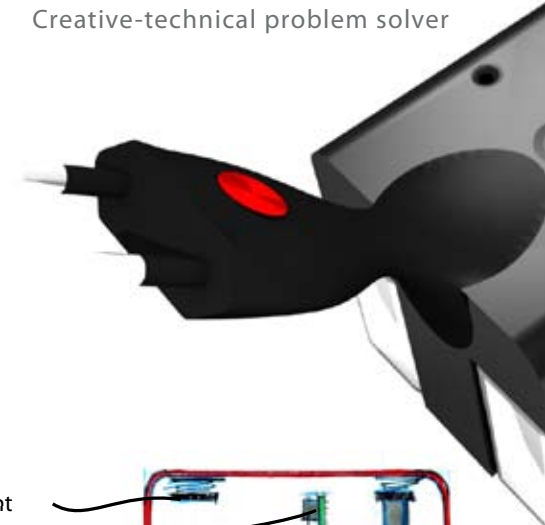
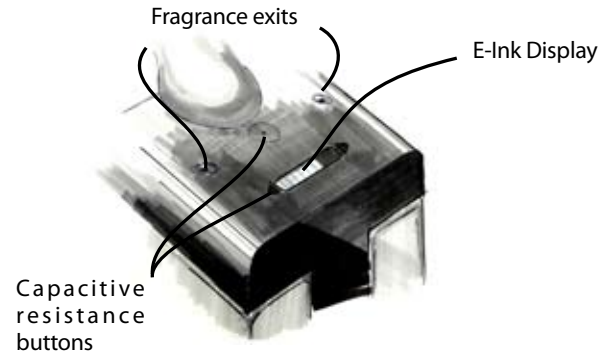

Final working model

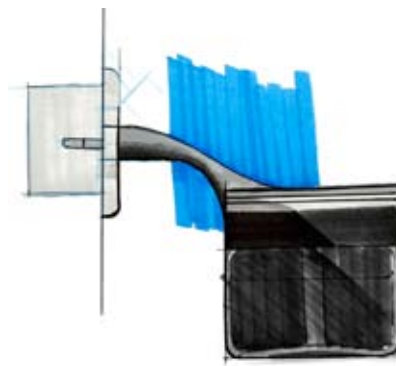

Usage: Recharging



## IPSon Compact

Open-source enclosure for computer - sensor interface used to develop musical instruments. Designed for adaptability and openness, all parts can be made in a FabLab.



## Manta Ray Blimp

Developed during a short skunkworks applied mechanics project, this helium filled blimp employs biomimicry to move. The total weight of the airship is 180 grams, including carbon fibre frame and electronics.



## Internet Ice Robot

How about handing out an ice cream to random passersby on the street, over the internet? This fully automated robot was built to promote a new flavour of Unilever's premium Ben & Jerry's ice cream, Web 2.0 style.



## Wallstream

From idea to prototype in a weekend: open-source narrowcasting with a twist. Using an integrated RFID reader, users can access their personal social information and updates from any connected screen.



## Laptop sleeve

Stylish, lightweight and robust protection for your laptop. Made from carbon fibre and leather, this sleeve really protects your laptop while on-the-go without sacrificing your mobility.



## Bob-up

Elderly people can use some help when using a walking caddy. Trying to walk up a curb, for instance, can be near impossible. Bob-up uses a complex mechanism to lift the caddy up using its forward motion. The product is easily attached to the front of any existing caddy and can be folded away when not in use.



## CabFabLab

A daily dose of rapid manufacturing: While helping set up The Hague's Fab Lab, I assisted people in designing and manufacturing endless models and prototypes.



## Personal Navigator

An electronic guide for urban environments: this navigator uses GPS and routing software to point its user to interesting waypoints via the scenic route. All the user sees is a distance estimation and a simple compass that always shows the right way.

